

D320-01

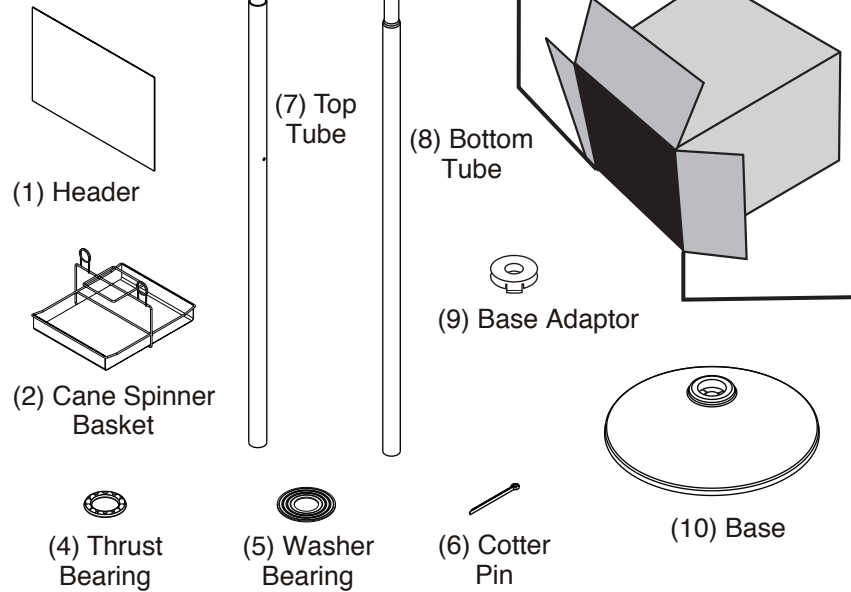

1 Attach Base Cap to Base

Insert Base Adaptor into Base. Make sure 3 tabs from Base Adaptor are snapped in to lock into Base as shown.

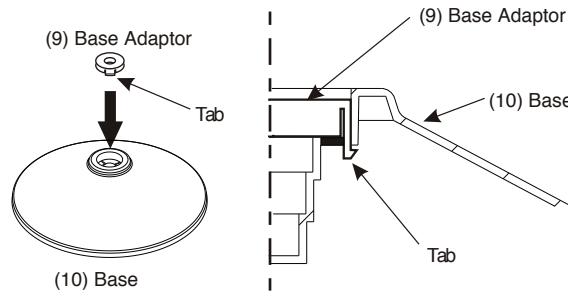

2 Attach Base and Tubes

Fit bottom Tube into top hole of Base as shown. Insert Top Tube onto Bottom Tube.

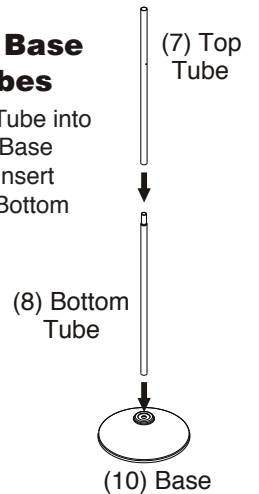

3 Attach Bearings

Insert Cotter Pin into hole of Top Tube, then place Washer Bearing and Thrust Bearing through Top Tube.

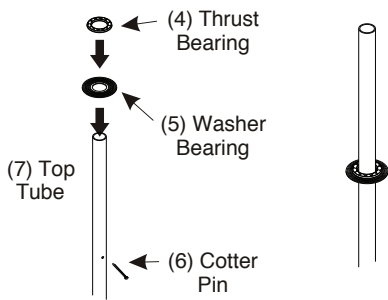

4 Assemble Basket and Rack

Insert Cane Spinner Basket first, then Cane Spinner Rack through top of Top Tube as shown.

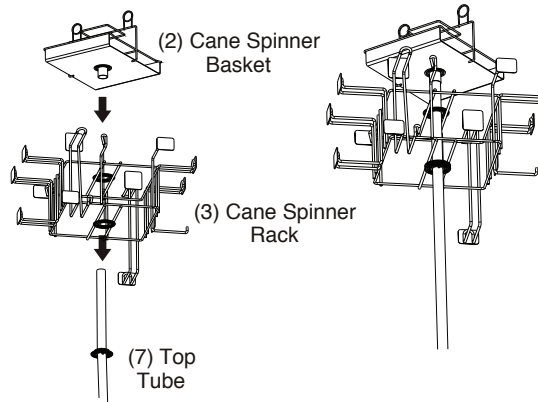

5 Insert Header

Finally, insert Header into holder on top of Cane Spinner Basket. Display is now ready for merchandise.

